

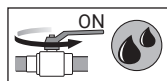

## 1° TEST



### PER CARTUCCIA E TUBI (H-C)

#### Attenzione!

Durante il test la cartuccia deve essere in **posizione chiusa**.

### FOR CARTRIDGE AND PIPES (H-C)

#### Attention!

During test, the cartridge must be in **closed position**.

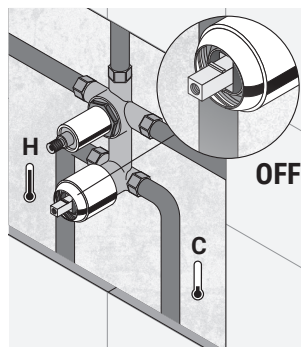

## 2° TEST

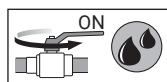

### PER DEVIATORE E TUBI (W1-W2-W3)

#### Attenzione!

Secondo la norma europea EN817, in caso di test per il deviatore e i tubi, la pressione deve essere a 4 bar per 1 minuto e la cartuccia in **posizione aperta**.

### FOR DIVERTER AND PIPES (W1-W2-W3)

#### Attention!

According to the European Standard EN817, in case of test for the diverter and the pipes, the pressure must be at 4 bar for 1 minute, and the cartridge in **open position**.

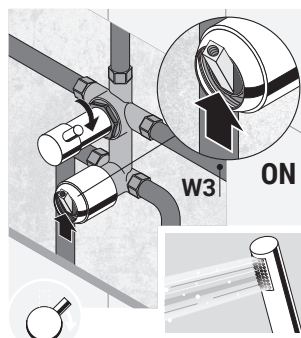
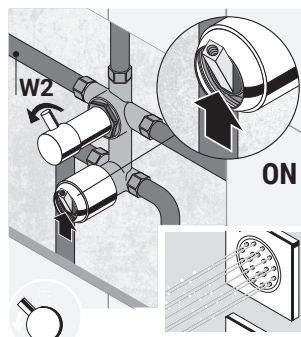
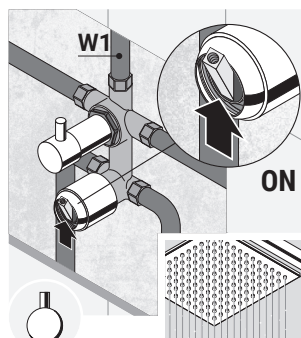

**H** = Acqua calda  
Hot water

**C** = Acqua fredda  
Cold water

**W1** = Acqua soffione  
Water for shower head

**W2** = Acqua body jet  
Water for body jet

**W3** = Acqua doccia  
Water for handshower

## Cura del prodotto / Product care

Water Alcohol Microfiber Detergent Sponge



L'impiego di prodotti non consigliati può deteriorare irrimediabilmente le superfici. Emmevi Rubinetterie S.r.l. non risponderà del danno.

Incorrect cleaning may permanently ruin the surface of the products. Emmevi Rubinetterie S.r.l. may not be held liable for damage.

cod. C00233

**emmevi**  
rubinetterie

Istruzioni di montaggio  
Installation instructions  
Montageanleitung  
Instructions de montage  
Руководство по монтажу  
Керівництво по монтажу

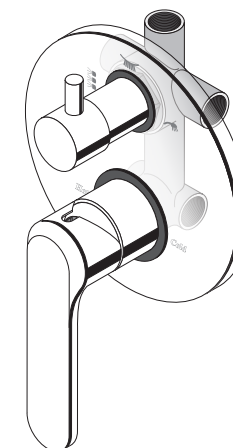

**Emmevi Rubinetterie S.r.l.**

Via Brughiere, 38 - 28017 San Maurizio d'Opaglio  
(NO) Italy

Tel. +39 0322 950157  
Fax +39 0322 967531

info@emmevi.it  
www.emmevi.it

## Prima di iniziare / Before starting

Pressure - BAR



Temperature - Degree



Non inclusi - Not included



## Installazione / Installation

1

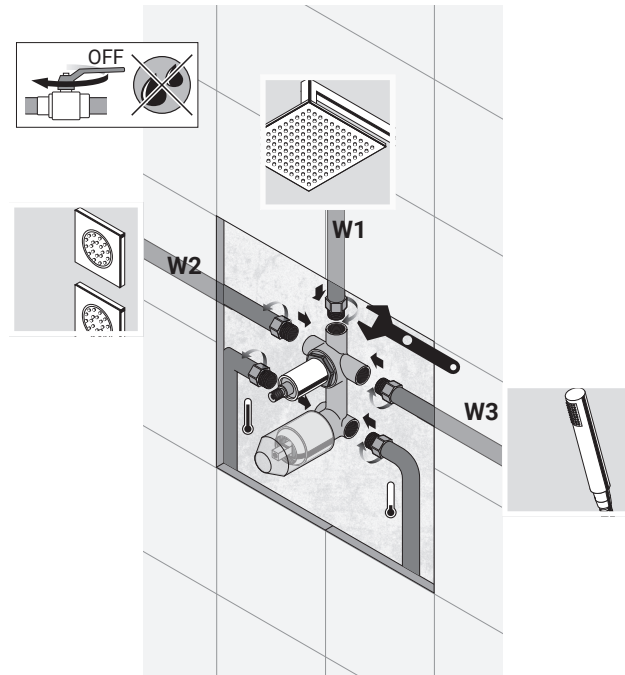

2

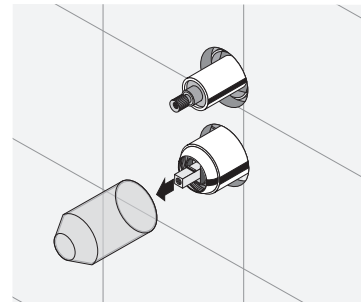

3

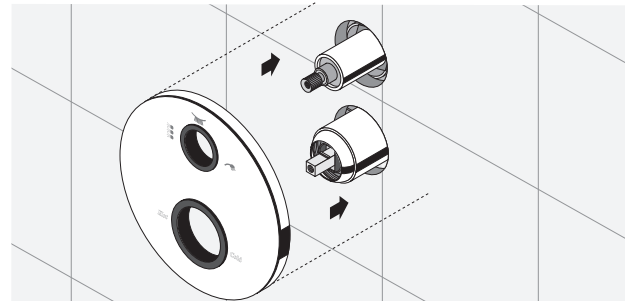

4

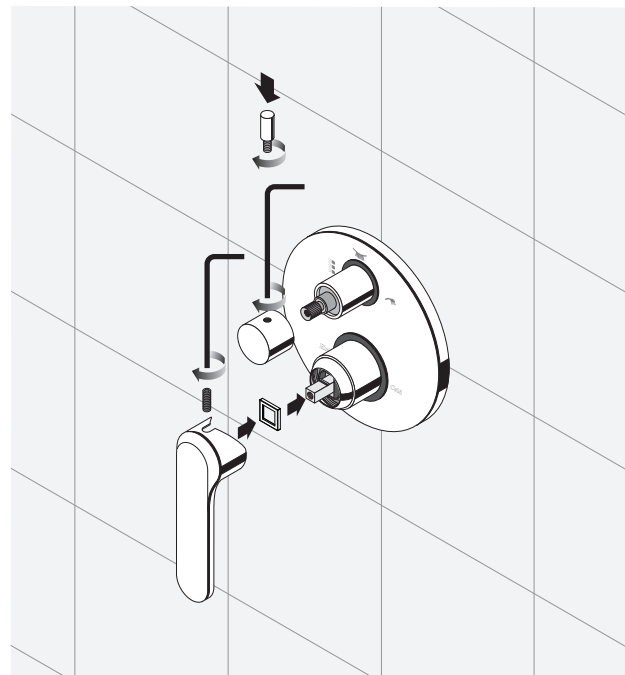

## Deviatore / Diverter

5

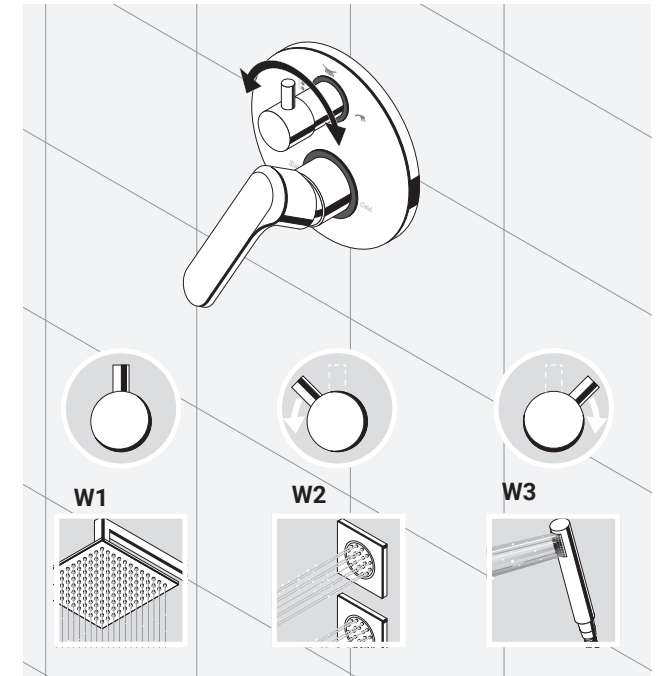

## Cartuccia / Cartridge

